

MODEL	BF-V700
Standby Power (50Hz)	560KW / 700KVA
Prime Power (50Hz)	505KW / 631KVA

Standard Features

General Features:

Engine (VOLVO TWD1643GE)
 Radiator 55°C max, fans are driven by belt, with safety guard
 24V charge alternator
 Alternator: single bearing alternator IP23, insulation class H/H
 Absorber
 Dry type air filter, fuel filter, oil filter, pre-filter, coolant filter
 Main line circuit breaker
 Standard control panel
 Oil drain pump
 Two 12V batteries, rack and cable
 Ripple flex exhaust pipe, exhaust siphon, flange, muffler
 User manual



PHOTO FOR REFERENCE ONLY

Generator Ratings

Voltage	HZ	Phase	P.F (COS ϕ)	Standby Amps	Standby Ratings (KW/KVA)	Prime Ratings (KW/KVA)
440/254	50	3	0.8	918	560/700	505/631
415/240	50	3	0.8	973	560/700	505/631
400/230	50	3	0.8	1010	560/700	505/631
380/220	50	3	0.8	1063	560/700	505/631

Prime Power (PRP): Prime power is available for an unlimited number of annual hours in variable load application, in accordance with GB/T2820-97 (eqv ISO8528); A 10% overload capability is available for a period of 1 hour within a 12-hour period of operation.

Standby Power Rating (ESP): The standby power rating is applicable for supplying emergency power for the duration of a utility power interruption. No overload, utility parallel or negotiated outage operation capability is available at this rating.

Sales Promises

Baifa Power provides a full line of brand new and high quality products. Each and every unit is strictly factory tested.

Warranty is according to our standard conditions: a, 15 months, counted on the day BAIFA sold to the first buyer; b, One year after installation; c, 1000 running hours (accumulated); subject to the earlier one. Service and parts are available from Baifa Power or distributors in your location.

ENGINE DATA

Manufacturer / Model:	VOLVO TWD1643GE, 4-cycle
Air Intake System:	Turbo, Water charge Air Cooling
Fuel System:	Elec. Injection, Elec. Fuel System
Cylinder Arrangement:	6 in line
Displacement:	16.12L
Bore and Stroke:	144*165 (mm)
Compression Ratio:	16.5
Rated RPM:	1500rpm
Max. Standby Power at Rated RPM:	596KW/811HP (with fan)
Governor Type:	EMS2

Exhaust System

Exhaust Gas Flow:	111.8m ³ /min
Exhaust Temperature:	463°C
Max Back Pressure:	10kPa

Air Intake System

Max Intake Restriction:	5kPa
Burning Capacity:	46.96 m ³ /min
Air Flow:	780m ³ /min

Fuel System

100%(Prime Power) Load:	199 g/KWh
75%(Prime Power) Load:	196 g/KWh
50%(Prime Power) Load:	196 g/KWh
100%(Prime Power) Load:	124.4L/h

Oil System

Total Oil Capacity:	48L
Oil Consumption:	0.11L/h
Engine Oil Tank Capacity:	32~42L
Oil Pressure at Rated RPM:	300-650kPa

Cooling System

Total Coolant Capacity:	128L
Thermostat:	82-92°C
Max Water Temperature:	103°C

ALTERNATOR SPECIFICATION**GENERAL DATA**

Compliance with GB755, BS5000, VDE0530, NEMAMG1-22, IED34-1, CSA22.2 and AS1359 standards.

Alternator Data

Number of Phase:	3
Connecting Type:	3 Phase and 4 Wires, "Y" type connecting
Number of Bearing:	1
Power Factor:	0.8
Protection Grade:	IP23
Altitude:	≤1000m
Exciter Type:	Brushless, self-exciting
Insulation Class, Temperature Rise:	H/H
Telephone Influence Factor (TIF):	<50
THF:	<2%
Alternator Capacity:	635KVA
Alternator Efficiencies:	95.1%

GENERATING SET DATA

Voltage Regulation:	≥±5%
Voltage Regulation, Stead State:	≤±1%
Sudden Voltage Warp (100% Sudden Reduce):	≤+20%
Sudden Voltage Warp (Sudden Increase):	≤-15%
Voltage Stable Time (100% Sudden Reduce):	≤4S
Voltage Stable Time (Sudden Increase)	≤4S
Frequency Regulation, Stead State:	≤5% Adjustable
Frequency Waving:	≤0.5%
Sudden Frequency Warp (100% Sudden Reduce):	≤+10%
Sudden Frequency Warp (Sudden Increase):	≤-7%
Frequency Recovery Time (100% Sudden Reduce):	≤3S
Frequency Recovery Time (Sudden Increase):	≤3S
Noise Level:	117dB

Standard Features

- ◇ “COMAP” Standard Auto Control System
- ◇ Base Fuel Tank
- ◇ Oil Drain Pump
- ◇ MCCB
- ◇ Starting batteries (Maintenance-Free & Watering-Free) with connective wires
- ◇ Exhaust System(including until muffler)
- ◇ Special Coolant for Volvo
- ◇ Water Separator (Volvo)
- ◇ Documents

Options

- ◇ Daily Fuel Tank
- ◇ Battery Charger
- ◇ Engine Heater
- ◇ Alternator Heater
- ◇ Engine Air Intake Heater
- ◇ Permanent Magnet Generator(PMG)
- ◇ Rainproof Type
- ◇ Soundproof Type
- ◇ Trailer Type
- ◇ Spare Parts
- ◇ Remote Control Panel
- ◇ Automatic Transfer Switch
- ◇ Switch box
- ◇ Paralleling System

Dimension & Weight

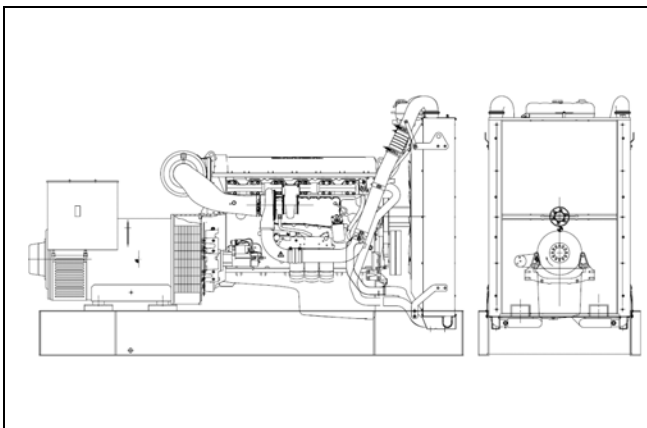

Standard Configuration (Open Type)

Overall Size: 3405*1397*1950 (mm)

Weight: 4050kg

With Base Fuel Tank

Overall Size: 3405*1397*2100 (mm)

Weight: 4350kg

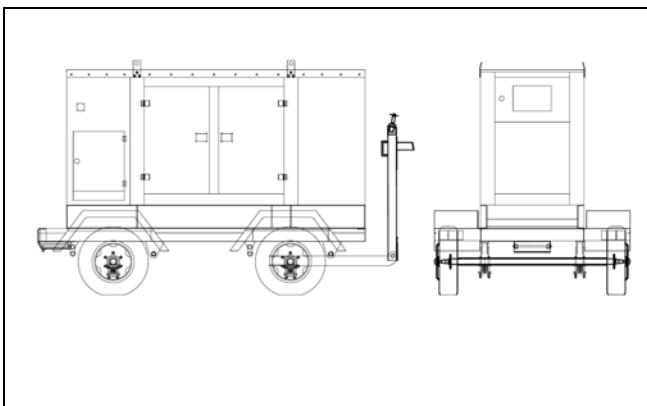

Soundproof Type

Overall Size: 5030*1660*2550 (mm)

Weight: 6060kg

Trailer Type

Overall Size: 5840*2540*3400 (mm)

Weight: 7510kg

Standard Control Panel



Baifa Standard Control Panel is the basic configuration for normal operation and usage, it is of some advantages such as easy to operate, various function and well protection. Operative buttons such as Turn On, Per-heat, Starting, Stop (Emergency Stop) on the panel. While malfunction occurs, control panel will stop the generator and also alarm with light or buzz.

Auto Module Control Panel



Auto Module Control Panel is the configuration for nobody on duty controlling generators. This kind of panel adopts auto module control system, with large LCD display to show the menu.

Features: MRS10-can receive remote output signal from ATS and realize auto start and stop of generators.

MRS16-can realize all functions of MRS10, add RS232 interface which can communicate with PC to realize remote operation.

AMF25-Auto Mains Failure controller, can realize all functions of MRS16, furthermore can detect ATS and control directly.

Auto Parallel Control Panel



Automatic Parallel Control Panel This new automatic parallel system adopts intelligent modules, inserted and folded installed, no need the peripheral relay and logic circuit. The main switch adopts electronic breaker or frame breaker, combined together with the generator, which is very reliable. One generator, one panel. The panel can be used both for singly and parallel. It is only need to parallel generator with such panel when the capability needs to be enlarged in the future.