

| MODEL                | BF-V415        |
|----------------------|----------------|
| Standby Power (50Hz) | 332KW / 415KVA |
| Prime Power (50Hz)   | 304KW / 380KVA |

### Standard Features

#### General Features:

Engine (VOLVO TAD1343GE)  
 Radiator 55°C max, fans are driven by belt, with safety guard  
 24V charge alternator  
 Alternator: single bearing alternator IP23, insulation class H/H  
 Absorber  
 Dry type air filter, fuel filter, oil filter, pre-filter, coolant filter  
 Main line circuit breaker  
 Standard control panel  
 Oil drain pump  
 Two 12V batteries, rack and cable  
 Ripple flex exhaust pipe, exhaust siphon, flange, muffler  
 User manual



PHOTO FOR REFERENCE ONLY

### Generator Ratings

| Voltage | HZ | Phase | P.F<br>( $\cos \phi$ ) | Standby<br>Amps | Standby<br>Ratings<br>(KW/KVA) | Prime<br>Ratings<br>(KW/KVA) |
|---------|----|-------|------------------------|-----------------|--------------------------------|------------------------------|
| 440/254 | 50 | 3     | 0.8                    | 544             | 332/415                        | 304/380                      |
| 415/240 | 50 | 3     | 0.8                    | 577             | 332/415                        | 304/380                      |
| 400/230 | 50 | 3     | 0.8                    | 599             | 332/415                        | 304/380                      |
| 380/220 | 50 | 3     | 0.8                    | 630             | 332/415                        | 304/380                      |

**Prime Power (PRP):** Prime power is available for an unlimited number of annual hours in variable load application, in accordance with GB/T2820-97 (eqv ISO8528); A 10% overload capability is available for a period of 1 hour within a 12-hour period of operation.

**Standby Power Rating (ESP):** The standby power rating is applicable for supplying emergency power for the duration of a utility power interruption. No overload, utility parallel or negotiated outage operation capability is available at this rating.

### Sales Promises

Baifa Power provides a full line of brand new and high quality products. Each and every unit is strictly factory tested.

Warranty is according to our standard conditions: a, 15 months, counted on the day BAIFA sold to the first buyer; b, One year after installation; c, 1000 running hours (accumulated); subject to the earlier one. Service and parts are available from Baifa Power or distributors in your location.

**ENGINE DATA**

|                                  |                                    |
|----------------------------------|------------------------------------|
| Manufacturer / Model:            | VOLVO TAD1343GE, 4-cycle           |
| Air Intake System:               | Turbo, Air/Air Cooling             |
| Fuel System:                     | Elec. Injection, Elec. Fuel System |
| Cylinder Arrangement:            | 6 in line                          |
| Displacement:                    | 12.78L                             |
| Bore and Stroke:                 | 131*158 (mm)                       |
| Compression Ratio:               | 18.1                               |
| Rated RPM:                       | 1500rpm                            |
| Max. Standby Power at Rated RPM: | 356KW/484HP (with fan)             |
| Governor Type:                   | EMS2                               |

**Exhaust System**

|                      |                         |
|----------------------|-------------------------|
| Exhaust Gas Flow:    | 60.0m <sup>3</sup> /min |
| Exhaust Temperature: | 420°C                   |
| Max Back Pressure:   | 10kPa                   |

**Air Intake System**

|                         |                         |
|-------------------------|-------------------------|
| Max Intake Restriction: | 5kPa                    |
| Burning Capacity:       | 27.0m <sup>3</sup> /min |
| Air Flow:               | 348m <sup>3</sup> /min  |

**Fuel System**

|                         |           |
|-------------------------|-----------|
| 100%(Prime Power) Load: | 192 g/KWh |
| 75%(Prime Power) Load:  | 193 g/KWh |
| 50%(Prime Power) Load:  | 200 g/KWh |
| 100%(Prime Power) Load: | 73.6L/h   |

**Oil System**

|                            |            |
|----------------------------|------------|
| Total Oil Capacity:        | 36L        |
| Oil Consumption:           | 0.04L/h    |
| Engine Oil Tank Capacity:  | 19~30L     |
| Oil Pressure at Rated RPM: | 370-520kPa |

**Cooling System**

|                         |         |
|-------------------------|---------|
| Total Coolant Capacity: | 44L     |
| Thermostat:             | 82-95°C |
| Max Water Temperature:  | 107°C   |

**ALTERNATOR SPECIFICATION****GENERAL DATA**

Compliance with GB755, BS5000, VDE0530, NEMAMG1-22, IED34-1, CSA22.2 and AS1359 standards.

**Alternator Data**

|                                     |  |
|-------------------------------------|--|
| Number of Phase:                    | 3  |
| Connecting Type:                    | 3 Phase and 4 Wires, "Y" type connecting |
| Number of Bearing:                  | 1  |
| Power Factor:                       | 0.8                                      |
| Protection Grade:                   | IP23                                     |
| Altitude:                           | ≤1000m                                   |
| Exciter Type:                       | Brushless, self-exciting                 |
| Insulation Class, Temperature Rise: | H/H                                      |
| Telephone Influence Factor (TIF):   | <50                                      |
| THF:                                | <2%                                      |
| Alternator Capacity:                | 400KVA                                   |
| Alternator Efficiencies:            | 93.4%                                    |

**GENERATING SET DATA**

|   |       |
|---|-------|
| Voltage Regulation:                           | ≥±5%  |
| Voltage Regulation, Stead State:              | ≤±1%  |
| Sudden Voltage Warp (100% Sudden Reduce):     | ≤+20% |
| Sudden Voltage Warp (Sudden Increase):        | ≤-15% |
| Voltage Stable Time (100% Sudden Reduce):     | ≤4S   |
| Voltage Stable Time (Sudden Increase)         | ≤4S   |
| Frequency Regulation, Stead State:            | ≤5%   |
| Frequency Waving:                             | ≤0.5% |
| Sudden Frequency Warp (100% Sudden Reduce):   | ≤+10% |
| Sudden Frequency Warp (Sudden Increase):      | ≤-7%  |
| Frequency Recovery Time (100% Sudden Reduce): | ≤3S   |
| Frequency Recovery Time (Sudden Increase):    | ≤3S   |
| Sound Pressure LP at 1m:                      | 115dB |

### Standard Features

- ◇ “COMAP” Standard Auto Control System
- ◇ Base Fuel Tank
- ◇ Oil Drain Pump
- ◇ MCCB
- ◇ Starting batteries ( Maintenance-Free & Watering-Free) with connective wires
- ◇ Exhaust System( including until muffler)
- ◇ Special Coolant for Volvo
- ◇ Water Separator (Volvo)
- ◇ Documents

### Options

- ◇ Daily Fuel Tank
- ◇ Battery Charger
- ◇ Engine Heater
- ◇ Alternator Heater
- ◇ Engine Air Intake Heater
- ◇ Permanent Magnet Generator(PMG)
- ◇ Rainproof Type
- ◇ Soundproof Type
- ◇ Trailer Type
- ◇ Spare Parts
- ◇ Remote Control Panel
- ◇ Automatic Transfer Switch
- ◇ Switch box
- ◇ Paralleling System

### Dimension & Weight

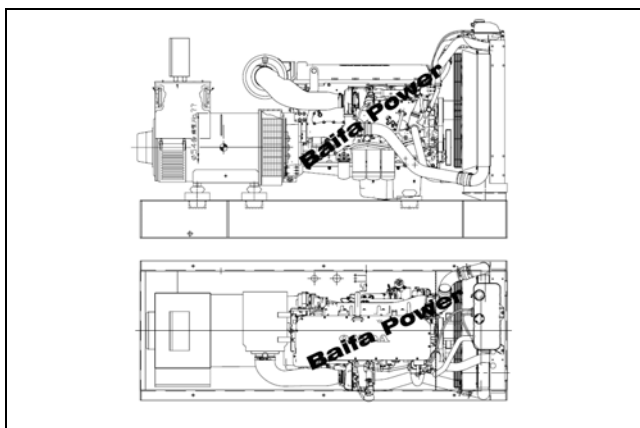

#### Standard Configuration (Open Type)

Overall Size: 3130\*1115\*1800 (mm)

Weight: 2900kg

#### With Base Fuel Tank

Overall Size: 3130\*1115\*1850 (mm)

Weight: 3000kg

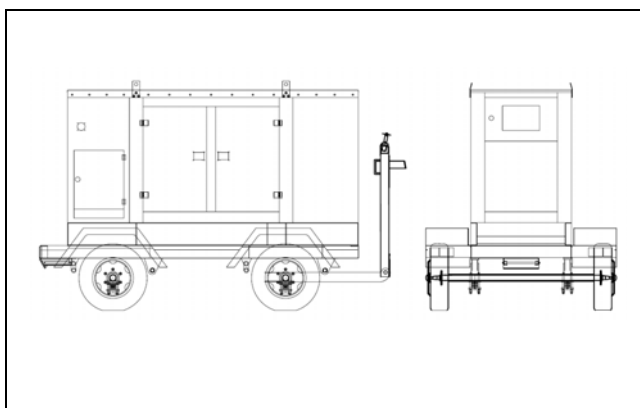

#### Soundproof Type

Overall Size: 4225\*1460\*2150 (mm)

Weight: 4300kg

#### Trailer Type

Overall Size: 5030\*2440\*2880 (mm)

Weight: 5700kg

### Standard Control Panel



**Baifa Standard Control Panel** is the basic configuration for normal operation and usage, it is of some advantages such as easy to operate, various function and well protection. Operative buttons such as Turn On, Per-heat, Starting, Stop (Emergency Stop) on the panel. While malfunction occurs, control panel will stop the generator and also alarm with light or buzz.

### Auto Module Control Panel



**Auto Module Control Panel** is the configuration for nobody on duty controlling generators. This kind of panel adopts auto module control system, with large LCD display to show the menu.

Features: MRS10-can receive remote output signal from ATS and realize auto start and stop of generators.

MRS16-can realize all functions of MRS10, add RS232 interface which can communicate with PC to realize remote operation.

AMF25-Auto Mains Failure controller, can realize all functions of MRS16, furthermore can detect ATS and control directly.

### Auto Parallel Control Panel



**Automatic Parallel Control Panel** This new automatic parallel system adopts intelligent modules, inserted and folded installed, no need the peripheral relay and logic circuit. The main switch adopts electronic breaker or frame breaker, combined together with the generator, which is very reliable. One generator, one panel. The panel can be used both for singly and parallel. It is only need to parallel generator with such panel when the capability needs to be enlarged in the future.