

MODEL	BF-SC350-60
Standby Power (60Hz)	285KW/356KVA
Prime Power (60Hz)	264KW/330KVA

### Standard Features

#### General Features:

Engine (SCANIA DC9 65A 10-95)  
 Radiator 50°C max, fans are driven by belt, with safety guard  
 24V charge alternator  
 Alternator: single bearing alternator IP23, insulation class H/H  
 Absorber  
 Dry type air filter, fuel filter, oil filter, pre-filter  
 Main line circuit breaker  
 Standard control panel  
 Oil drain pump  
 Two 12V batteries, rack and cable  
 Ripple flex exhaust pipe, exhaust siphon, flange, muffler  
 User manual



PHOTO FOR REFERENCE ONLY

### Generator Ratings

Voltage	HZ	Phase	P.F (COS $\phi$ )	Standby Amps	Standby Ratings (KW/KVA)	Prime Ratings (KW/KVA)
480/277	60	3	0.8	428	285/356	264/330
460/266	60	3	0.8	446	285/356	264/330
440/254	60	3	0.8	467	285/356	264/330
416/240	60	3	0.8	494	285/356	264/330

**Prime Power (PRP):** Prime power is available for an unlimited number of annual hours in variable load application, in accordance with GB/T2820-97 (eqv ISO8528) ; A 10% overload capability is available for a period of 1 hour within a 12-hour period of operation.

**Standby Power Rating (ESP):** The standby power rating is applicable for supplying emergency power for the duration of a utility power interruption. No overload, utility parallel or negotiated outage operation capability is available at this rating.

### Sales Promises

Baifa Power provides a full line of brand new and high quality products. Each and every unit is strictly factory tested.

Warranty is according to our standard conditions: a, 15 months, counted on the day BAIFA sold to the first buyer; b, One year after installation; c, 1000 running hours (accumulated); subject to the earlier one. Service and parts are available from Baifa Power or distributors in your location.

### ENGINE DATA

Manufacturer / Model:	SCANIA DC9 65A 10-95, , 4-cycle
Air Intake System:	Turbo, Air/Air Cooling
Fuel System:	Elec. Injection
Cylinder Arrangement:	5 in line
Displacement:	8.87L
Bore and Stroke:	127×140 (mm)
Compression Ratio:	18:1
Rated RPM:	1800rpm
Max. Standby Power at Rated RPM:	315KW
Governor Type:	EMS

#### Exhaust System

Exhaust Gas Flow:	26Kg/min
Exhaust Temperature:	539°C
Max Back Pressure:	10kPa

#### Air Intake System

Max Intake Restriction:	5kPa
Burning Capacity:	25Kg/min
Air Flow:	450m <sup>3</sup> /min

#### Fuel System

100%(Prime Power) Load:	202 g/KWh
75%(Prime Power) Load:	203 g/KWh
50%(Prime Power) Load:	205 g/KWh
100%(Prime Power) Load:	67.5 L/h

#### Oil System

Oil Consumption:	<0.3 g/KWh
Engine Oil Tank Capacity:	37L
Oil Pressure at Rated RPM:	300-600kPa

#### Cooling System

Total Coolant Capacity:	57L
Thermostat:	83°C
Max Water Temperature:	105°C

**ALTERNATOR SPECIFICATION****GENERAL DATA**

Compliance with GB755, BS5000, VDE0530, NEMAMG1-22, IED34-1, CSA22.2 and AS1359 standards.

**Alternator Data**

Number of Phase:	3
Connecting Type:	3 Phase and 4 Wires, "Y" type connecting
Number of Bearing:	1
Power Factor:	0.8
Protection Grade:	IP23
Altitude:	≤1000m
Exciter Type:	Brushless, self-exciting
Insulation Class, Temperature Rise:	H/H
Telephone Influence Factor (TIF):	<50
THF:	<2%
Voltage Regulation, Steady State:	≤±1%
Alternator Capacity:	360KVA
Alternator Efficiencies:	93.0%
Air Cooling Flow:	0.99m <sup>3</sup> /s

**GENERATING SET DATA**

Voltage Regulation:	≥±5%
Voltage Regulation, Stead State:	≤±1%
Sudden Voltage Warp (100% Sudden Reduce):	≤+20%
Sudden Voltage Warp (Sudden Increase):	≤-15%
Voltage Stable Time (100% Sudden Reduce):	≤4S
Voltage Stable Time (Sudden Increase)	≤4S
Frequency Regulation, Stead State:	≤5%
Frequency Waving:	≤0.5%
Sudden Frequency Warp (100% Sudden Reduce):	≤+10%
Sudden Frequency Warp (Sudden Increase):	≤-7%
Frequency Recovery Time (100% Sudden Reduce):	≤3S
Frequency Recovery Time (Sudden Increase):	≤3S

### Standard Features

- ◇ “COMAP” Standard Auto Control System
- ◇ Starting batteries( Maintenance-Free & Watering-Free) with connective wires
- ◇ Exhaust System( including until muffler)
- ◇ MCCB
- ◇ Water Separator
- ◇ Documents
- ◇ Special Coolant
- ◇ Oil Drain Pump

### Options

- ◇ Base Fuel Tank
- ◇ Daily Fuel Tank
- ◇ Battery Charger
- ◇ Engine Heater
- ◇ Alternator Heater
- ◇ Permanent Magnet Generator(PMG)
- ◇ Rainproof Type
- ◇ Soundproof Type
- ◇ Trailer Type
- ◇ Engine Air Intake Heater
- ◇ Remote Control Panel
- ◇ Automatic Transfer Switch
- ◇ Switch box
- ◇ Paralleling System
- ◇ Spare Parts

### Dimension & Weight

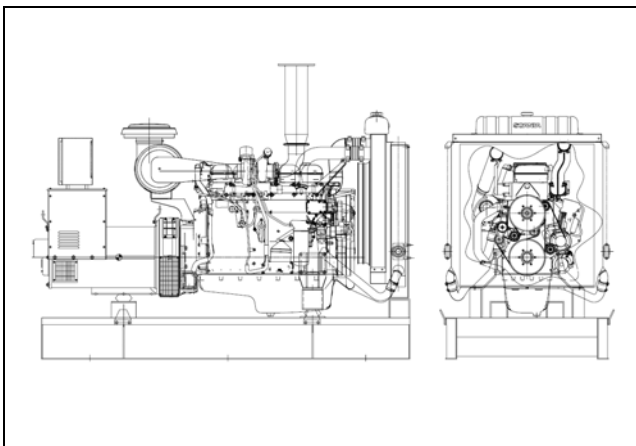

#### Standard Configuration (Open Type)

Overall Size: 2840(mm)×1270(mm)×1790(mm)  
Weight: 2360kg

#### With Base Fuel Tank

Overall Size: 2840(mm)×1270(mm)×1795(mm)  
Weight: 2385kg

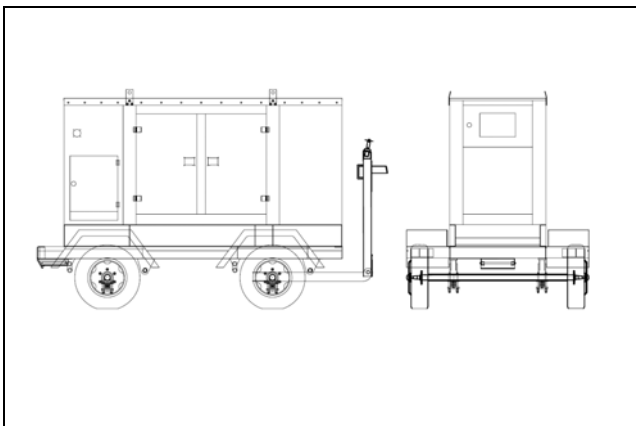

#### Soundproof Type

Overall Size: 4225(mm)×1460(mm)×2150(mm)  
Weight: 3275kg

#### Trailer Type

Overall Size: 5030(mm)×2440(mm)×2880(mm)  
Weight: 4625kg

### Auto Module Control Panel



**Auto Module Control Panel** is the configuration for nobody on duty controlling generators. This kind of panel adopts auto module control system, with large LCD display to show the menu.

Features: MRS10-can receive remote output signal from ATS and realize auto start and stop of generators.

MRS16-can realize all functions of MRS10, add RS232 interface which can communicate with PC to realize remote operation.

AMF25-Auto Mains Failure controller, can realize all functions of MRS16, furthermore can detect ATS and control directly.

### Auto Parallel Control Panel



**Automatic Parallel Control Panel** This new automatic parallel system adopts intelligent modules, inserted and folded installed, no need the peripheral relay and logic circuit. The main switch adopts electronic breaker or frame breaker, combined together with the generator, which is very reliable. One generator, one panel. The panel can be used both for singly and parallel. It is only need to parallel generator with such panel when the capability needs to be enlarged in the future.