

MODEL	BF-P1875-60
Standby Power (60Hz)	1500KW/1875KVA
Prime Power (60Hz)	1360KW/1710KVA

### Standard Features

#### General Features:

Engine ( Perkins 4012-46TAG3A )  
 Radiator 50°C max, fans are driven by belt, with safety guard  
 24V charge alternator  
 Alternator: single bearing alternator IP23, insulation class H/H  
 Absorber  
 Dry type air filter, fuel filter, oil filter  
 Main line circuit breaker  
 Standard control panel  
 batteries, rack and cable  
 Ripple flex exhaust pipe, exhaust siphone, flange, muffler  
 User manual



PHOTO FOR REFERENCE ONLY

### Generator Ratings

Voltage	HZ	Phase	P.F (COS $\phi$ )	Standby Amps	Standby Ratings (KW/KVA)	Prime Ratings (KW/KVA)
480/277	60	3	0.8	2255	1500/1875	1360/1710
460/266	60	3	0.8	2353	1500/1875	1360/1710
440/254	60	3	0.8	2460	1500/1875	1360/1710
416/240	60	3	0.8	2602	1500/1875	1360/1710

**Prime Power (PRP):** Prime power is available for an unlimited number of annual hours in variable load application, in accordance with GB/T2820-97 (eqvISO8528) ; A 10% overload capability is available for a period of 1 hour within a 12-hour period of operation.

**Standby Power Rating (ESP):** The standby power rating is applicable for supplying emergency power for the duration of a utility power interruption. No overload, utility parallel or negotiated outage operation capability is available at this rating.

### Sales Promises

Baifa Power provides a full line of brand new and high quality products. Each and every unit is strictly factory tested.

Warranty is according to our standard conditions: 12 months or 1,000 running hours, subject to the earlier one.

Service and parts are available from Baifa Power or distributors in your location.

**ENGINE DATA**

Manufacturer / Model:	Perkins 4012-46TAG3A, 4-cycle
Air Intake System:	Turbocharged, air to air charge cooled
Fuel Injection System:	Direct Injection
Cylinder Arrangement:	12 in V type
Displacement:	45.842L
Bore and Stroke:	160×190 (mm)
Compression Ratio:	13
Rated RPM:	1800rpm
Max. Standby Power at Rated RPM:	1643KW
Governor Type:	Electronic

**Exhaust System**

Exhaust Gas Flow(after turbo):	336m <sup>3</sup> /min
Exhaust Temperature:	434°C
Max Back Pressure:	5kPa

**Air Intake System**

Max Intake Restriction:	5kPa
Consumption:	145m <sup>3</sup> /min
Air Flow:	2160m <sup>3</sup> /min

**Fuel System**

100%( Prime Power) Load:	213g/KWh
75%(Prime Power) Load:	221g/KWh
50%(Prime Power) Load:	222g/KWh
100%( Prime Power) Load:	399L/H

**Oil System**

Total Engine Oil Capacity:	177L
Engine Oil Tank Capacity:	157.5L
Min Oil Pressure at Rated RPM:	340kPa

**Cooling System**

Total Coolant Capacity:	210L
Thermostat:	71- 85 °C
Max top tank Temperature:	101°C

**ALTERNATOR SPECIFICATION****GENERAL DATA**

Compliance with GB755,BS5000,VDE0530,NEMA MG1-22,IEC-34,CSA C22-100and AS1359 standards.

**Alternator Data**

Number of Phase:	3
Connecting Type:	3 Phase and 4 Wires, "Y" type connecting
Number of Bearing:	1
Power Factor:	0.8
Protection Grade:	IP23
Altitude:	≤1000m
Exciter Type:	Brushless, self-exciting
Insulation Class, Temperature Rise:	H/H
Telephone Influence Factor (TIF):	<50
THF:	<2%
Alternator Capacity:	1815KVA
Alternator Efficiencies:	95.2%

**GENERATING SET DATA**

Voltage Regulation:	≥±5%
Voltage Regulation, Stead State:	≤±1%
Sudden Voltage Warp (100% Sudden Reduce):	≤+25%
Sudden Voltage Warp (Sudden Increase):	≤-20%
Voltage Stable Time (100% Sudden Reduce):	≤6S
Voltage Stable Time (Sudden Increase)	≤6S
Frequency Regulation, Stead State:	≤5%
Frequency Waving:	≤1%
Sudden Frequency Warp (100% Sudden Reduce):	≤+12%
Sudden Frequency Warp (Sudden Increase):	≤-10%
Frequency Recovery Time (100% Sudden Reduce):	≤5S
Frequency Recovery Time (Sudden Increase):	≤5S

### Standard Features

- ◇ Baifa Standard Auto Control System
- ◇ Oil Drain Valve
- ◇ Documents
- ◇ Starting batteries ( Maintenance-Free & Watering-Free) with connective wires
- ◇ Exhaust System( including until muffler)
- ◇ Base Fuel Tank

### Options

- ◇ Daily Fuel Tank
- ◇ Battery Charger
- ◇ Engine Heater
- ◇ Alternator Heater
- ◇ Water Separator
- ◇ Remote Control Panel
- ◇ Rainproof Type
- ◇ Soundproof Type
- ◇ Trailer Type
- ◇ Automatic Transfer Switch
- ◇ Switch box
- ◇ Spare Parts

### Dimension & Weight

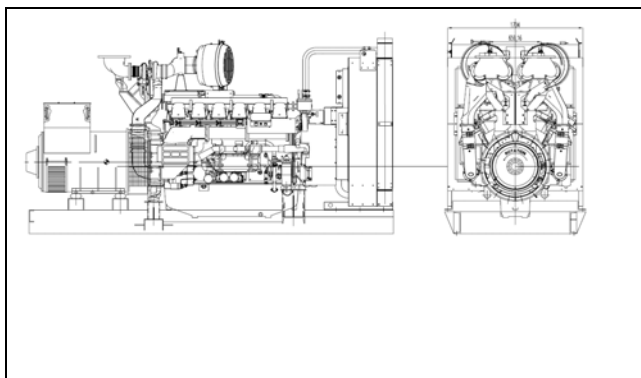

#### Open Type

Overall Size: 5100\*2200\*2850 mm

Weight: 12800 kg

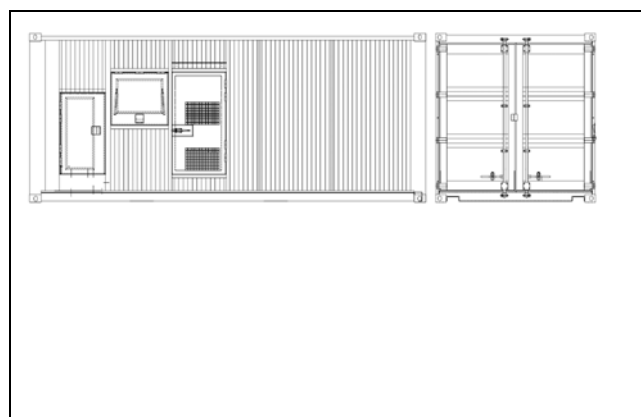

#### Soundproof Type (ISO 20'ft GP)

Overall Size: : 12192×2438×2896mm

Weight: 17800 kg

### Auto Module Control Panel



**Auto Module Control Panel** is the configuration for nobody on duty controlling generators. This kind of panel adopts auto module control system, with large LCD display to show the menu.

Features: MRS10-can receive remote output signal from ATS and realize auto start and stop of generators.

MRS16-can realize all functions of MRS10, add RS232 interface which can communicate with PC to realize remote operation.

AMF25-Auto Mains Failure controller, can realize all functions of MRS16, furthermore can detect ATS and control directly.

### Auto Parallel Control Panel



**Automatic Parallel Control Panel** This new automatic parallel system adopts intelligent modules, inserted and folded installed, no need the peripheral relay and logic circuit. The main switch adopts electronic breaker or frame breaker, combined together with the generator, which is very reliable. One generator, one panel. The panel can be used both for singly and parallel. It is only need to parallel generator with such panel when the capability needs to be enlarged in the future.