

MODEL	BF-M2750
Standby Power (50Hz)	2200KW / 2750KVA
Prime Power (50Hz)	2000KW / 2500 KVA

### Standard Features

- General Features:
- Engine (MTU 20V4000G23)
  - Radiator 40°C max, fans are driven by motor, with safety guard
  - 24V charge alternator
  - Alternator: single bearing alternator IP23, insulation class H/H
  - Absorber
  - Dry type air filter, fuel filter, oil filter
  - Permanent Magnet Generator (PMG)
  - Standard control panel
  - Four 12V batteries, rack and cable
  - Ripple flex exhaust pipe, exhaust siphon, flange, muffler
  - User manual



PHOTO FOR REFERENCE ONLY

### Generator Ratings

Voltage	HZ	Phase	P.F (COS Ø)	Standby Amps	Standby Ratings (KW/KVA)	Prime Ratings (KW/KVA)
440/254	50	3	0.8	3609	2200/2750	2000/2500
415/240	50	3	0.8	3826	2200/2750	2000/2500
400/230	50	3	0.8	3969	2200/2750	2000/2500
380/220	50	3	0.8	4178	2200/2750	2000/2500

Prime Power (PRP): Prime power is available for an unlimited number of annual hours in variable load application, in accordance with GB/T2820-97 (eqv ISO8528); A 10% overload capability is available for a period of 1 hour within a 12-hour period of operation.

Standby Power Rating (ESP): The standby power rating is applicable for supplying emergency power for the duration of a utility power interruption. No overload, utility parallel or negotiated outage operation capability is available at this rating.

### Sales Promises

Baifa Power provides a full line of brand new and high quality products. Each and every unit is strictly factory tested.

Warranty is according to our standard conditions: a, 15 months, counted on the day BAIFA sold to the first buyer; b, One year after installation; c, 1000 running hours (accumulated); subject to the earlier one. Service and parts are available from Baifa Power or distributors in your location.

**ENGINE DATA**

Manufacturer / Model:	MTU/20V4000G23
Air Intake System:	Turbo, Water/Air Cooling
Fuel System:	Electronic Fuel Injection System
Cylinder Arrangement:	20 in "V"
Displacement:	95.4L
Bore and Stroke:	170*210 (mm)
Compression Ratio:	16.4
Rated RPM:	1500rpm
Max. Standby Power at Rated RPM:	2420KW (without fan)
Governor Type:	ADEC

**Exhaust System**

Exhaust Gas Flow:	438m <sup>3</sup> /min
Exhaust Temperature:	530°C
Max Back Pressure:	8.5kPa

**Air Intake System**

Max Intake Restriction:	5kPa
Burning Capacity:	162m <sup>3</sup> /min
Intake Flow:	2196m <sup>3</sup> /min

**Fuel System**

100%(Prime Power) Load:	195 g/kwh
75%(Prime Power) Load:	201 g/kwh
50%(Prime Power) Load:	213 g/kwh
100%(Prime Power) Load:	495L/h

**Oil System**

Total Oil Capacity:	390L
Oil Consumption:	0.5% Fuel Consumption
Engine Oil Tank Capacity:	245~340L
Oil Pressure at Rated RPM:	480-740kPa

**Cooling System**

Engine Coolant Capacity:	260L
Thermostat:	79°C
Max Water Temperature:	104°C

**ALTERNATOR SPECIFICATION****GENERAL DATA**

Compliance with GB755, BS5000, VDE0530, NEMAMG1-22, IED34-1, CSA22.2 and AS1359 standards.

**Alternator Data**

Number of Phase:	3
Connecting Type:	3 Phase and 4 Wires, "Y" type connecting
Number of Bearing:	1
Power Factor:	0.8
Protection Grade:	IP23
Altitude:	≤1000m
Exciter Type:	Brushless, self-exciting
Insulation Class, Temperature Rise:	H/H
Telephone Influence Factor (TIF):	<50
THF:	<2%
Voltage Regulation, Steady State:	≤±1%
Alternator Capacity:	2500KVA
Alternator Efficiencies:	96%

**GENERATING SET DATA**

Voltage Regulation:	≥±5%
Voltage Regulation, Stead State:	≤±1%
Sudden Voltage Warp (100% Sudden Reduce):	≤+20%
Sudden Voltage Warp (Sudden Increase):	≤-15%
Voltage Stable Time (100% Sudden Reduce):	≤4S
Voltage Stable Time (Sudden Increase)	≤4S
Frequency Regulation, Stead State:	0-5% adjustable
Frequency Waving:	≤0.5%
Sudden Frequency Warp (100% Sudden Reduce):	≤+10%
Sudden Frequency Warp (Sudden Increase):	≤-7%
Frequency Recovery Time (100% Sudden Reduce):	≤3S
Frequency Recovery Time (Sudden Increase):	≤3S
Noise Level:	118dB

### Standard Features

- ◇ “COMAP” Standard Auto Control System
- ◇ Permanent Magnet Generator(PMG)
- ◇ Oil Drain Valve
- ◇ Documents
- ◇ Battery Charger
- ◇ Starting batteries ( Maintenance-Free & Watering-Free) with connective wires
- ◇ Exhaust System( including until muffler)
- ◇ Special Coolant
- ◇ Water Separator
- ◇ Engine Heater

### Options

- ◇ Daily Fuel Tank
- ◇ Alternator Heater
- ◇ Spare Parts
- ◇ Automatic Transfer Switch
- ◇ Rainproof Type
- ◇ Soundproof Type
- ◇ Trailer Type
- ◇ Remote Control Panel
- ◇ Paralleling System
- ◇ Switch box

### Dimension & Weight

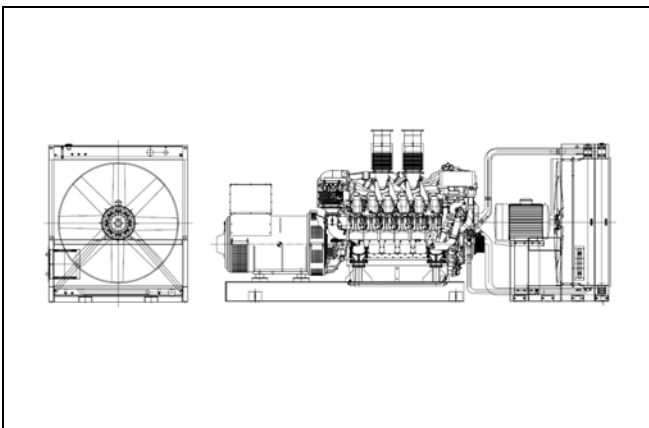

#### Standard Configuration (Without Radiator)

Overall Size: 6250×2320×2500 (mm)  
Weight:18500kg

#### Standard Configuration (With Radiator)

Overall Size: 8300×2950×2550 (mm)  
Weight: 20500kg

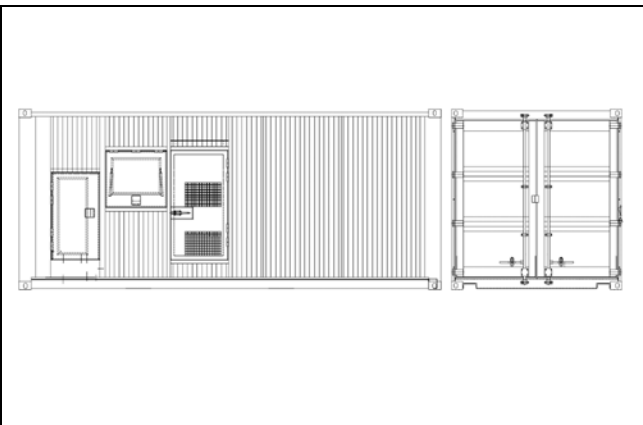

#### Soundproof Type (Standard 40'ft high container)

Overall Size:12192×2438×2896 (mm)  
Weight:26000kg

### Auto Module Control Panel



**Auto Module Control Panel** is the configuration for nobody on duty controlling generators. This kind of panel adopts auto module control system, with large LCD display to show the menu.

Features: MRS10-can receive remote output signal from ATS and realize auto start and stop of generators.

MRS16-can realize all functions of MRS10, add RS232 interface which can communicate with PC to realize remote operation.

AMF25-Auto Mains Failure controller, can realize all functions of MRS16, furthermore can detect ATS and control directly.

### Auto Parallel Control Panel



**Automatic Parallel Control Panel** This new automatic parallel system adopts intelligent modules, inserted and folded installed, no need the peripheral relay and logic circuit. The main switch adopts electronic breaker or frame breaker, combined together with the generator, which is very reliable. One generator, one panel. The panel can be used both for singly and parallel. It is only need to parallel generator with such panel when the capability needs to be enlarged in the future.